

LED Spotlight Bulb



INTRODUCTION

Features:

1. High efficiency and energy conservation, in the same bright, LED spotlight bulb is 1 kwh per 1000hrs, incandescent lamp is 1 kwh per 17 hrs, the halogen lamp is 1 kwh per 100hrs.
2. Beauty appearance, practical, great heat dissipation, high brightness, low brightness declines.
3. LED spotlight bulb doesn't contain mercury and other harmful substances, non-UV light without flicker, protection your eyes isn't easy to fatigue, no noise, ensure that the use of comfort and security.

Applications :

Suitable for showcase windows, cafes, restaurants, gift shop artwork, museum and deparment stores for merchandise displaying. Also good for family living room and bedroom's lighting and decoration.



GN-HP-WW1W4-MR16

NAMING RULES

GN - HP - WW 1W4 - MR16

- Company name:G-NOR(GN)
- Product category:High Power LED
- Color
- LED Qty.
- Base

SPECIFICATIONS

Light source parameters

LED type	SMD R20 1W LED
Angle(θ)	30°
LED Qty	4PCS
Life Span	>30,000 hours

Electrical parameters

Luminous flux(lm)	360lm
Voltage	12VDC/AC
Power	4W

Appearance parameters

Size	50*52.5mm
Color	CW/WW/R/G/B/Y

Installation method

Base type	MR16
-----------	------

Environmental parameters

Working Temperature	-30℃ - +60℃
Storage Temperature	-50℃ - +80℃
Warranty	24Months

SIZE

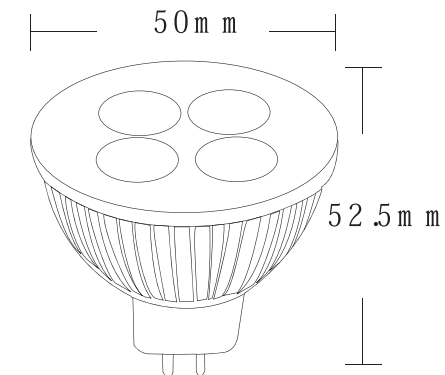

PACKING INFORMATION



Electrostatic bag size	50*50*60mm
Outside packing carton	225*265*115mm
Packing Qty	36PCS
Net weight	1.6kg/1Box
Gross weight	1.8kg

CE RoHS